



TECHNOLOGIES OF ENCHANTMENT



WHEN A CERAMIC VASE AND A DRONE CRY TOGETHER

PATRICIA DOMÍNGUEZ

GASWORKS

We greet the 7 sacred directions:
North, South, East, West,
The centre of the Universe,
The centre of the Earth, Your own personal centre.

The browser is a vehicle for 'The Client'.
'The Client' has 16 inboxes
8 kinds of automatic answers
7 trash bins are stomachs to digest spam.

1

I met Señora Rosa while I was shooting my video, *Eyes of Plants*. Rosa told me she had a son who bio-transformed into a white man.

She is the direct descendent of a Mapuche chief, her grandfather. She married "a dark-skinned man, though *mino* (handsome)", who was a Special Investigations police officer. When she bore her fourth son, he left her (although he always regretted it, according to her).

Rosa's parents often talked about whether the *wawas* (babies) were white, or nearly white, or dark-skinned.

Though her husband was dark, her three first sons were white like her. But the fourth turned out to be dark. One day he caught hepatitis and became white.

"Well, not white-white", said Rosa, "he was rather yellow". Her son wanted so hard to belong that his body underwent a process of bio-whitening.

Not unlike Jacko, the King of Pop.

*Rosa, your story is a real bio-drama.
Rosa, your son's bio-depigmentation
is a myth.*

*Rosa, I will make a bio-video for you about
the myth of bio-tears.*

There are 700 opportunities and projects.
For each opportunity,
there are 4 roses.

WATER: TEARS COSMIC WEEPING

My first encounter with indigenous worlds was through a *jarro pato* (a duck-shaped ceramic vase) belonging to the Diaguita culture. ¹ We stared at each other through the glass display cabinet that safeguards my grandfather's collection of pre-Columbian objects.

My grandfather's cabinet is a multi-universe where many worlds meet. It's a portal where past and present connect through ancestral vases. The ceramics in my grandfather's collection were produced by the Diaguita people in the late Farmer-Potter Period, which ran from approximately 1.300 A.D. to thirty-two years before the arrival of the first Spaniards to America.

The *jarro pato* is a ritual vessel in the shape of a duck. It is an animal figure, even though it has human features. It is a musical instrument and a prayer for sacred waters, so scarce in the desert. Some duck-shaped vases are depicted weeping, three tears falling down from each of their eyes. And from the ceramic vase, these tears run down into a river of cosmic weeping. We all have cried the exact same recycled waters. The same tears running down the cheeks of indigenous peoples run also through the cheeks of settler-colonists, eventually falling down from the eyes of our contemporaries, glued to the screens of their mobile phones. *Little by little, all these tears have reshaped my face.*

The duck-shaped vase in my grandfather's cabinet is a vortex. It's a portal into an oceanic flow of ancestral liquids that has brought us here, from one uterus to another. We are nothing but a link in a chain of births. H2O.

This ceremonial vase was buried in a tomb for thousands of years until it was sacked. According to my grandfather, three construction workers found it by chance while building a road in La Serena. They were convinced that it contained a treasure, so they smashed it. There was nothing inside, of course.

Later an anthropologist put together the shards, which the three men had divided up among themselves. It did not occur to them that the treasure could be in those tears.

I took care of the *jarro pato* while I was shooting my video, *Eyes of Plants*. Let me be clear about this, the vase shouldn't be here in the first place. It should rest in peace with its original owner. But it was extracted from the earth long ago and now it's displayed inside a cabinet in a privately-owned house.

During the shooting, I would sit every day before my altar, burn incense and light some candles to honour the vase. My altar allows me to take refuge in the earth.

Before returning the vase, I sat down to channel its energy. Channelling means connecting oneself to another entity so as to call down intangible energies. Following one's instinct or intuition, people usually assign an image, a word, a sound or a sensation to what has yet to be named. In order to channel their energy, one connects oneself to another person or object feeling through him or her (or it). I had no idea that I could channel an object, until my teacher at Frecuencia Licán healing school taught me a few years ago.

When I channelled the *jarro pato*, I became that vessel. But now this object stared back at me. I could see myself through its ancestral eyes. I saw a little girl staring at me through my grandfather's glass cabinet. I recognised that girl and I could see her growing up in the old house at Calle Colón. Then in the house at Calle Santa Blanca. Then at Cerro San Luis. I saw myself through its eyes and through the glass cabinet. It never occurred to me that a vase could be a witness to my life. Now I understand that this crying duck stands witness to bygone eras and civilisations. But it's also a witness to my family and others, observing in silence through the glass cabinet in my grandparents' house.

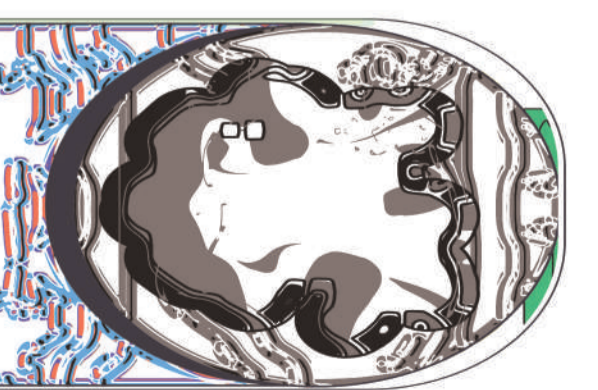
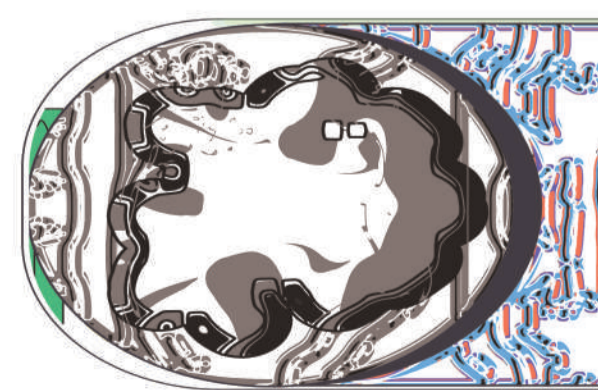
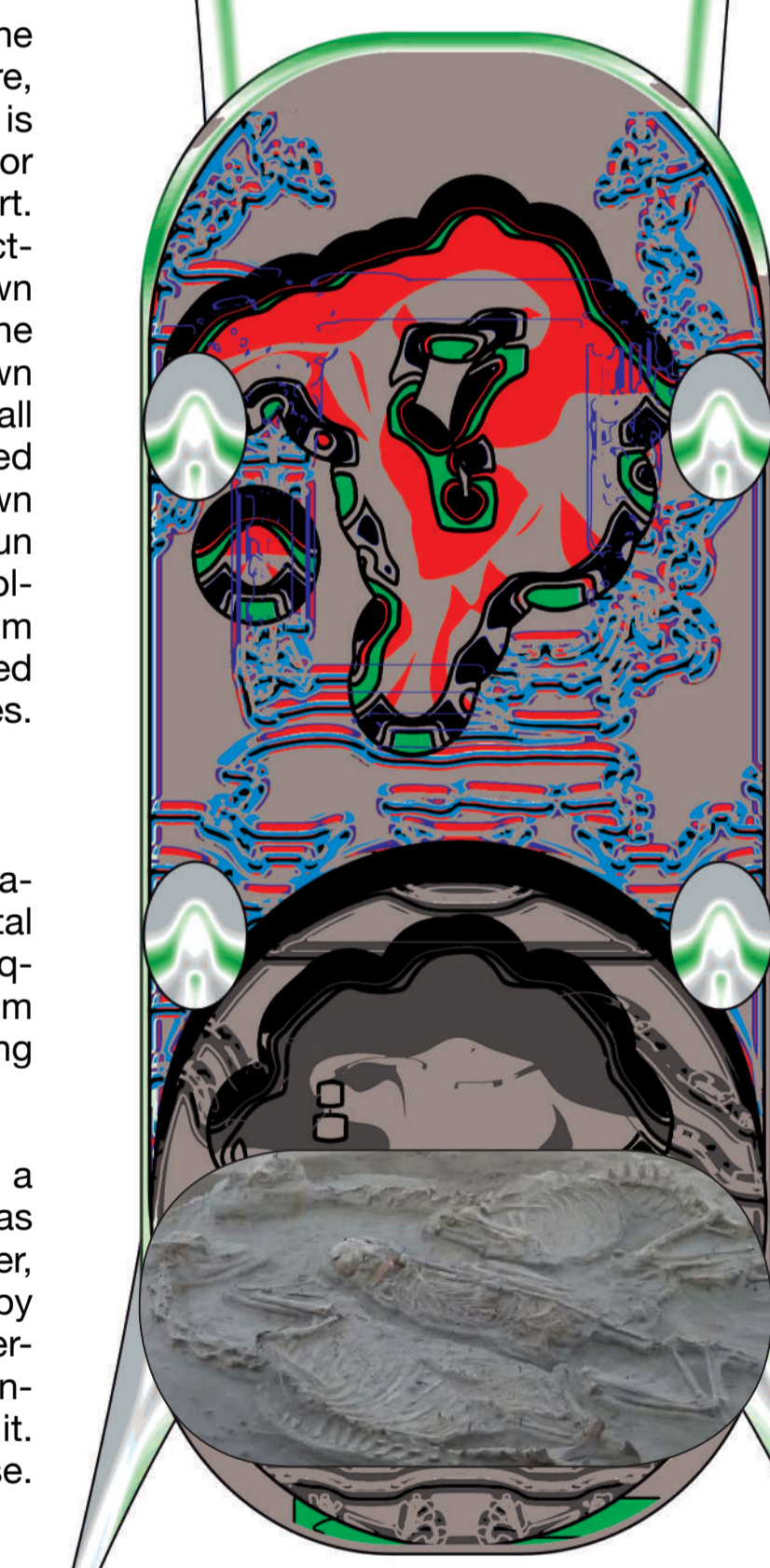

¹ The Diaguita people is a farmer-potter indigenous culture native to the Chilean Norte Chico and the Argentine Northwest.

Western or Chilean Diaguitas lived mainly in what are now the regions of Atacama and Coquimbo.

Each rose
has 32 petals and each petal
has 64 people working on it.

WATER: D.N.A TORRENT

Last Christmas I gave a DNA test to my grandmother as a gift. Both my grandma and my saliva are the custodians of my DNA, my *ancestral liquids*. As I watched her spit into a plastic container for the DNA test, I had a vision (not a hallucination, but a vision). I saw a pool of water swirling down into the centre of the Earth. While staying afloat, I looked downwards and I saw my ancestors.



4

I understood that the pond was made of my saliva and that I'm carrying each and every one of my ancestors with me. Likewise, you are carrying yours in your mouth. These are the primal waters running down the stream of life. *These waters sweep along those who are the closest to me, those who pass through me. You too are being carried by primal waters.*

SHAPESHIFTING lines

Once I finished shooting the video, I put the *jarro pato* back in its cabinet. That very night, I dreamed about the vase. In my dreams, I visited a museum built underground. It was cold and dark inside. The museum walls were all metallic grey and I could only distinguish rows and rows of display cabinets dimly lit by LED lights. The cabinets contained white corporate shirts with thin blue stripes.

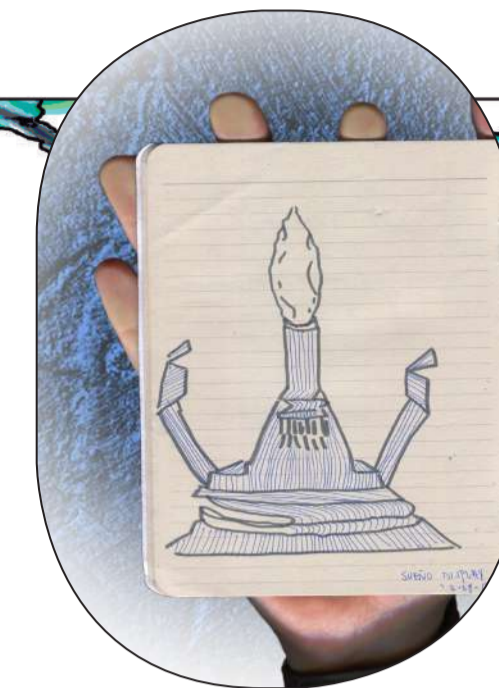

8

The shirts had been meticulously folded in such way that they formed abstract and geometric designs so wonderful that they resembled origami. They had been starched and were stiff enough to hold all the pre-Columbian objects from my grandfather's collection.



5

*ALL YOUR ANCESTORS ARE
WITHIN YOU.
EACH OF THEM LIVES IN A POOL OF
ANCESTRAL WATERS.
IN THE POOL OF YOUR SALIVA.
ONE CAN RECREATE THEIR
ANCESTORS FROM THEIR SALIVA.
YOUR ANCESTORS ACCOMPANY YOU,
SURROUND YOU, DEFINE YOU.
THEY ALL GAVE THE BEST OF
THEMSELVES, SO THAT
YOU MAY EXIST.
LET US CLEANSE THESE WATERS.*



6



7

OH, EARTH! GOOD EARTH.
UNPRODUCTIVE, SILENT EARTH.
THERE ARE NO TREASURES BENEATH THE
GROUND, BUT ONLY CONSUMED BODIES
WAITING TO BE HEALED.
EARTH IS ENTRUSTED
WITH HEALING OUR SORROWS.

I looked closer into one of the cabinets. Resting on the upper folds of a business shirt, I could see a black obsidian knife crowning a pyramid made of dozens of blue-striped corporate shirts.

The duck-shaped vase was in another cabinet. But it rested on someone's torso, a nondescript someone who was wearing a pink-and-white striped shirt. On a second glance, I noticed that this person was rubbing the vase against his or her back. The vase had healing properties and eased their pain. I then noticed other office workers and businessmen who were also rubbing pre-Columbian pottery over their exhausted bodies, looking for some relief, brushing the passing of time from their weary bones.

My eyes squinted as I tried to focus simultaneously on the geometric designs of the pre-Columbian pottery and the regular stripes in the business shirts.

11

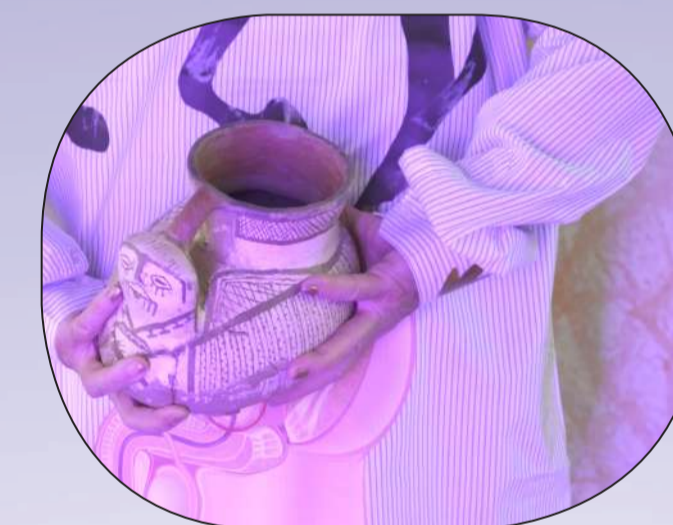

9

As they combined into a single stereoscopic image, new patterns emerged. I understood that the abstract patterns from those ceramics had mutated into the stripes in the shirts. I recognised new cosmologies and hybrid patterns taking shape in this geometry.

For the Diaguita people, the lines painted in zig-zag, ripples and chain-like patterns that decorate their pottery were like visual litanies or mantras. These geometric designs provided an order to their world. Likewise, the thin stripes in today's corporate shirts are not just ornamental. They convey a way of ordering the world. Namely, the neoliberal world-order. These stripes outline the arms of employees while they are signing invoices or investment contracts. *Like the lines in a legal contract, the stripes in business shirts are no less straight, regular, orderly.*



10



12

Each female worker is wearing a shirt.
Each shirt has 640 blue stripes.
Each stripe is a path for 3 horses and a
motorcycle moving fast.
Not minding where they go.

Inside their running hooves
there is an eye that weeps.
For each eye
there are 2 hands comforting them.

Within each hand
there is a forest of trees
waiting to be made into 1,000,000,000
sheets of paper.

These hands activate 7 lights, 7 options.
There are roses to heal the past
and only one rose to heal the future
Present, past and future
are being cleansed.

Within each person there are 160 passwords,
2,823 images placed in order to express themselves, 320 inflamed organs.
Each ancestor has its colon.
Within each colon there is a person removing thorns from the skin.
One by one.

It takes minutes for a contract signed in Europe to set into motion natural resources in Chile. Forests disappear, cities flourish in the desert, the courses of rivers are altered, ancestral cemeteries are replaced by garbage dumps, new industrial suns light up the sky twenty-four hours a day without interruption.

However, restless productivity does not come free. Back pain is pretty much inevitable for those who sit all day in front of a computer. Blue light emitted by screens is harmful for your eyes. Typing produces joint pains. Bones ache. While financial markets run at full speed, our bodies are left behind.

The last time I was in London, I explored the financial centre of Canary Wharf, a privately-owned commercial state in the Isle of Dogs. British writer Iain Sinclair has described the Isle of Dogs as "a Hong Kong principality with its own private security. Lands disappear and you get this financial centre that's just been parachuted in from somewhere else and it isn't where it is. It sort of is there, but it isn't". I found

several healing centres, wellness facilities and prayer rooms hidden in the basements of the office buildings in Canary Wharf. They were concealed beneath the earth, guarded by her. The names of these places are telling: *Healing Earth Centre, Nomad Travel Clinic, Island Health Clinic, Freedom Clinic, Mobile Male Massage...* Above ground, in the streets and in the office blocks, appearances were kept up 24/7. Beneath the Earth's surface, office workers consumed by deadlines waited for their wounds to mend.

Earth's transformative potential is not just spiritual, but physical too. Think for example of mud poultices and how they have been used for thousands of years. These poultices appeal to the intelligence of earth. They can absorb toxins from the body, reduce inflammations and trigger processes of healing. When placed on a painful area, cold mud tempers any excessive heat from the body as it gets warmer and eventually dries. After each use, it can be sanitised just by exposing the mud to sunlight, since the sun's radiations have well-known antibacterial properties. The body knows about its bal-

ance and mud is an ally to restore it.

Years ago, I accompanied my ex-partner in his process of healing from a colon cancer. In case every other treatment failed (of the Western and non-Western types), it was suggested that he meet with a traditional healer in South Korea, who, as a last resort, would bury him for days until the earth brought his body back into balance.

*Restore his order.
His order.
Bring him back into balance.
Earth is a body hosting
other bodies.*

I have carried out research on some of the most comprehensive collections of pre-Columbian artefacts in Chile, Bolivia, Peru, Colombia, Mexico, United States, Britain, Netherlands and Spain. Most precolonial objects found on earth belong to these museums. They offer their geometric patterns as a gift to anyone who looks at them.

*My soul is traversed by these patterns
when I look at them.*

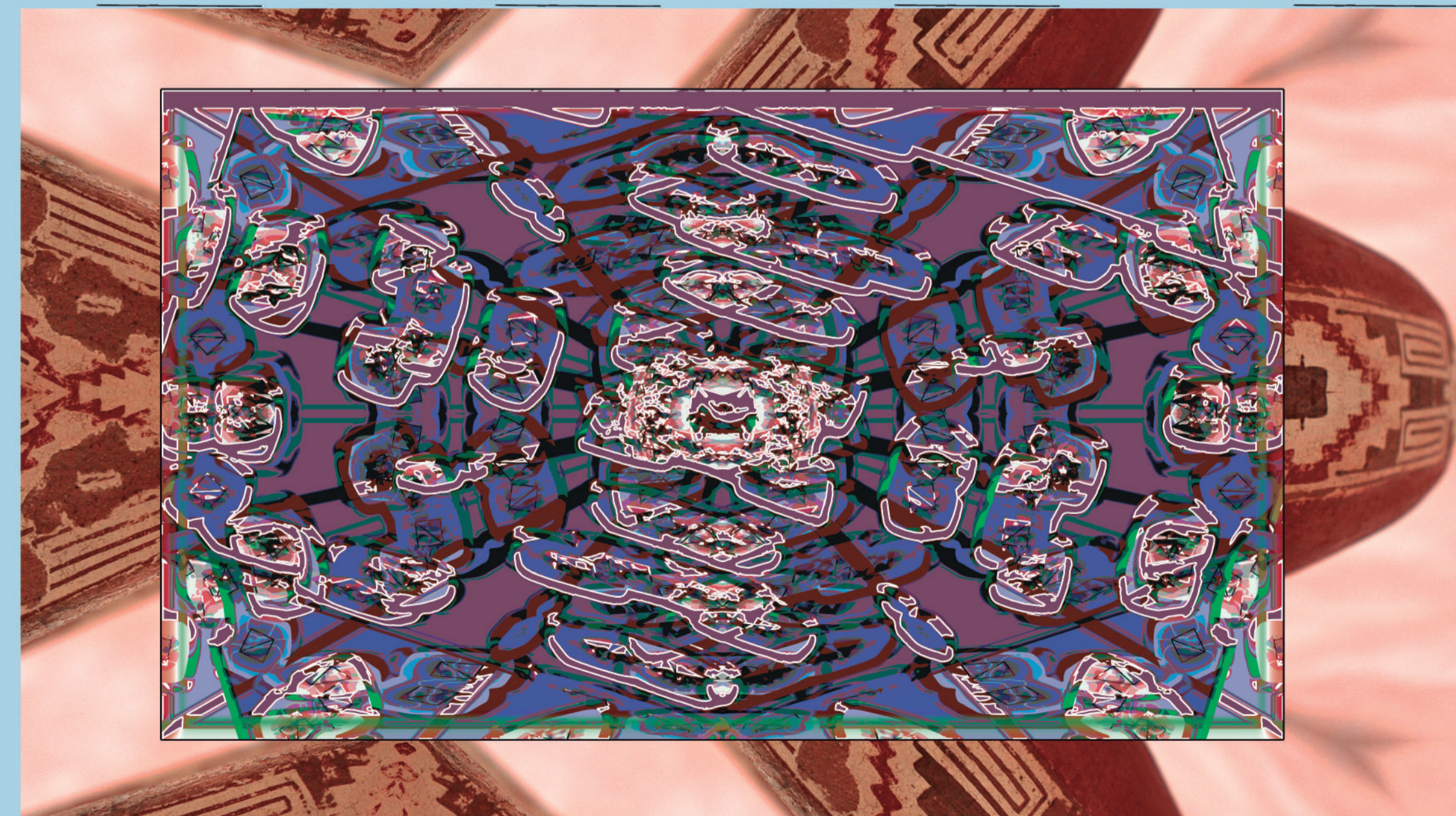
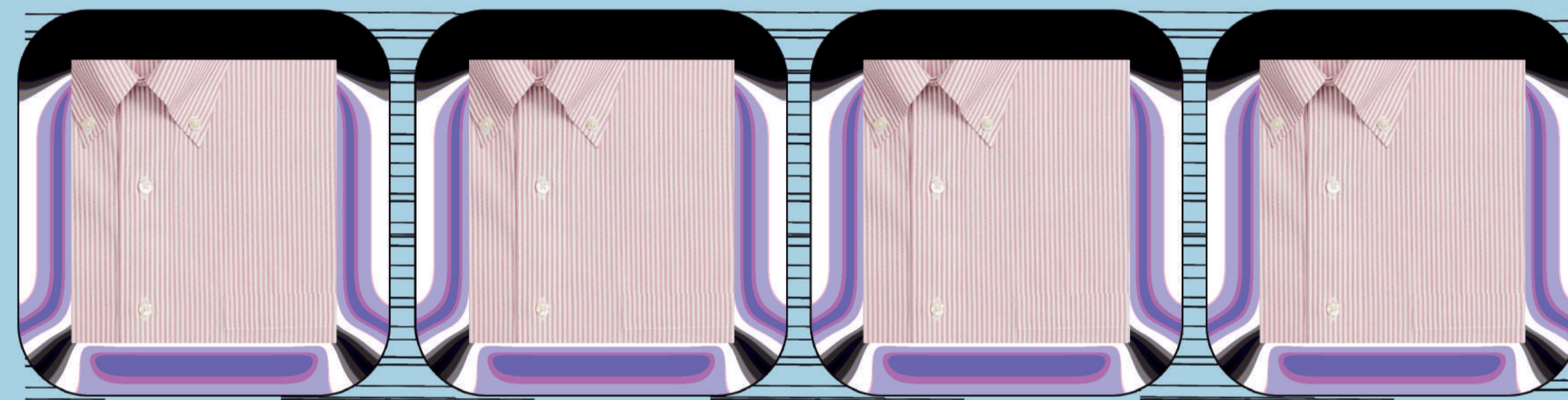

13

My spreadsheets hurt.

My chakras hurt.

Like fractals, pre-Columbian ceramics often look alike but they are never the same. Having spent so much time in archaeological museums, I have begun to recognise the hands of the artists that modelled them. Some are pretty easy to identify, for example the artist who made the sculptures of Xipe Tótec. They have the same look, the same faces, the same expression. One of them is on display at the Chilean Museum of Pre-Columbian Art, and another one belongs to the National Museum of Anthropology, in Mexico City.

The abstract patterns in this art are not just ornamental, but a synthesis of indigenous worlds. Each of these objects contains a microcosm within itself. The fear of emptiness (*horror vacui*) that led these artists to fill the entire surface of their ceramics with such intricate detail is a reminder of human search for meaning. According to archaeologist Paola González, the geometric patterns in Diaguita pottery were a visual technology of shamanic healing and hypnotic attraction. The pre-Incan visual art of the Diaguita, explains Paola, "does not pursue

a semantic end. Rather, we are dealing with *technologies of enchantment*, involving the use of optical illusions, such as non-mimetic animation, as a way to captivate viewers. Today, decorative patterns with similar characteristics still play a crucial role in shamanic healing for some indigenous communities in the Amazon... It's almost as if the eye comprehended senses of which the mind knew nothing".²

As the duck-shaped vase keeps spinning on its axis, the enchanting technology of its geometric patterns brings us to another dimension. We forget about deadlines. We escape from cyclical time. Black lines come forward, white lines recede and a new dimension unfolds before our eyes. Time and space open up in the ceramic vase, while its abstract patterns and geometric lines unfold throughout the body.

Let me quote from Paola's essay again; "as if the eye comprehended senses of which the mind knows nothing". After comparing the Diaguita and Shipibo designs, Paola concludes that abstract and symmetrical patterns have in both cases not only aesthetic, but

also therapeutic purposes: "The *kené* (sacred design) doesn't merely fulfill an aesthetic function, but it's also an active agent in the maintenance of the Shipibo's physical and spiritual health. Belaunde points out that both in the materialization of abstract designs on their bodies, and in the immaterial vision of the same designs during a shamanic session, the purpose is the embellishment of people and things by covering them with graphisms of plants. This ritual embellishment allows the Shipibo to heal from physical, psychological, social and spiritual forms of distress".³

Just like every plant and every person, each object has its own code. Depending on their specific energy, there are objects that soothe us, objects that induce delirium, objects that trigger action. Objects are portals and vortices. They transfer their energy to us as we look at them. Their geometry imprints a new order on your hologram.

*Graphisms of plants
Wrap around me!*

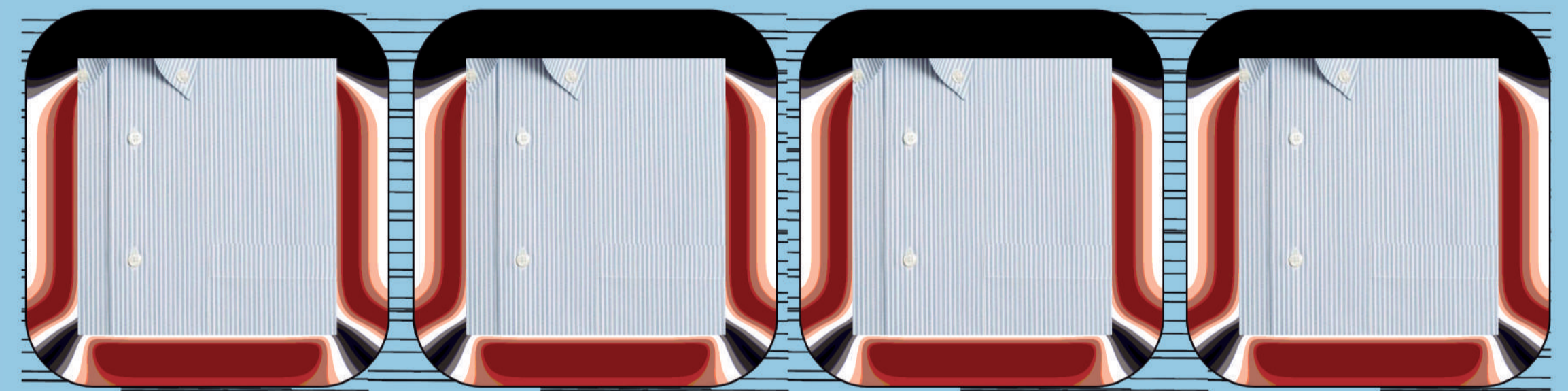

14

Within each thorn there is an Excel sheet.
Within the spreadsheets, 64 roses protect you from the electromagnetic waves
threatening to pierce your body.

The vase in the shape of a crying duck has 2 eyes.
Within its tears, there are 16,000 waterfalls.
Each waterfall contains the DNA of a different person.
10,000 ancestors swimming in your saliva.

[2] See Paola González, "Shipibo-Conibo shamanic art of the Peruvian amazon and its relation to the Diaguita culture of Chile" in *Boletín del Museo Chileno de Arte Precolombino*, no. 21 (2016).

[3] See Paola González.

EARTH RESETTING

Just as the duck-shaped vase is an intermediary between worlds, I was raised and still live in a *contact zone*⁴, a space of colonial encounters where different peoples come into contact and establish relations that transform them, and which are defined by a radical power imbalance. For those of us who inhabit contact zones, it is common to grow up rootless in a land where roots have been nearly eradicated, banished and corporatised. Even though we inhabit ancestral lands.

In my work, I have tried to reconnect with those roots from an uncomfortable position. It's an emic approach to my research, undertaken from within, where a cosmological thought lies not exempt from contradictions. I myself look more European than anything else. *Bio-pigmented, I have green eyes, eyes of plants.* I look white but my ancestry is a little more complex than that. Among my ancestors, there are those who chose to mix and those who were forced. Some may have been in love and some may have been

bored. It is likely that some were raped too, since a small percentage of me has inhabited these territories from time immemorial. But the rest of me was raised by neoliberalism.

Colonialism and the military dictatorship erased two of the five hard drives that stored the history of my country. I can't help but wonder what it would be like to recompose those erased memories, to reinvent forgotten myths from an erratic position, from a position that involves embracing complexity, staying with the trouble, inhabiting a danger zone. I would like to hold on to this problem, here. To test the elasticity of my contact zones. To speak from the position of someone who *shouldn't* be here, but was born here.

The Spaniards first arrived in Chile from the north, coming from what today is Peru, and shaking its foundations to the roots. No stone was left unturned, from land ownership to the ancestral cosmology of the four cardinal points. In the Mapuche worldview, each cardinal direction still corresponds to a symbolic space. Unsurprisingly, the north corresponds to the direction of terror.

That's where the conquistadors came from. I wonder what the north might have meant before colonial trauma? But it's a pointless question. Since then, indigenous ancestral knowledge has been turned into folklore, silenced, disregarded, made invisible.

Despite all this, the Pachamama is still alive in the form of a deep connection to the earth. Often involuntarily, this connection mutates and keeps transforming over time with the introduction of new technologies, but also as a result of natural resource extraction, foreign influence, cultural imports. The Pachamama continues under new forms and by other means. Postcolonial cosmologies are the result of a long chain of mistranslations, misappropriations and cultural misunderstandings that define everyday life here in the *contact zones*.

Folklore is the name of a colonial strategy. Folklore is a way for colonial elites to erase indigenous worlds and neutralise ancestral histories. It's a way to keep them contained, to relegate them to the margins, to exoticise them. Folklore is a way to freeze time, transforming open and unsolved historical processes into a souvenir for tourists. And yet, ancestral history is still happening. It is simply going down other roads, in unexpected ways.

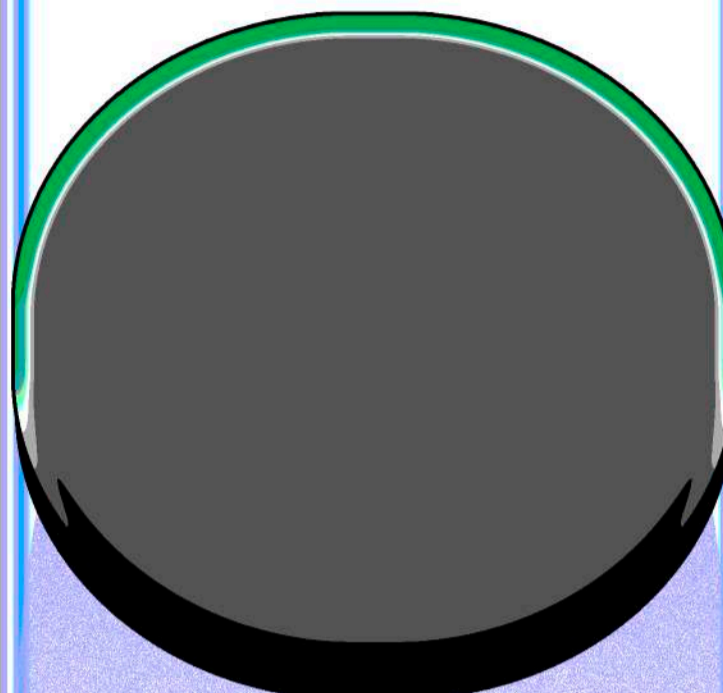
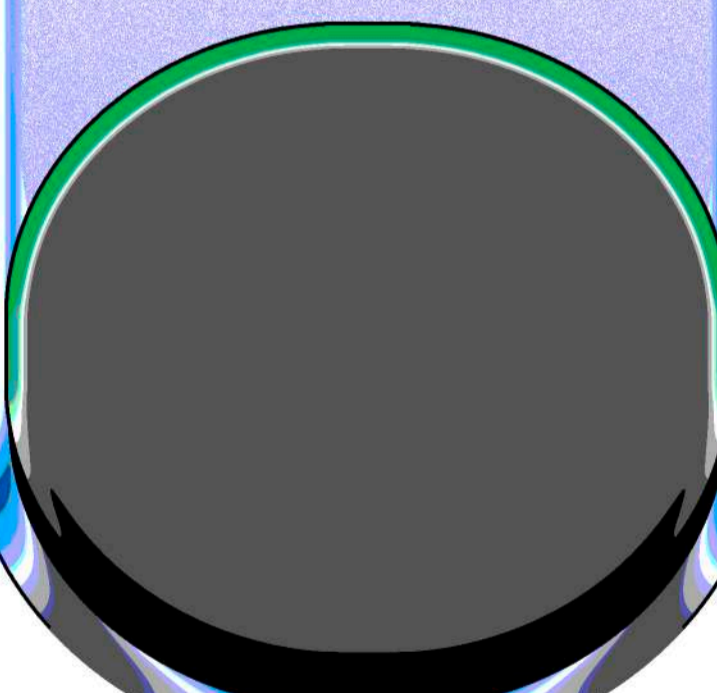
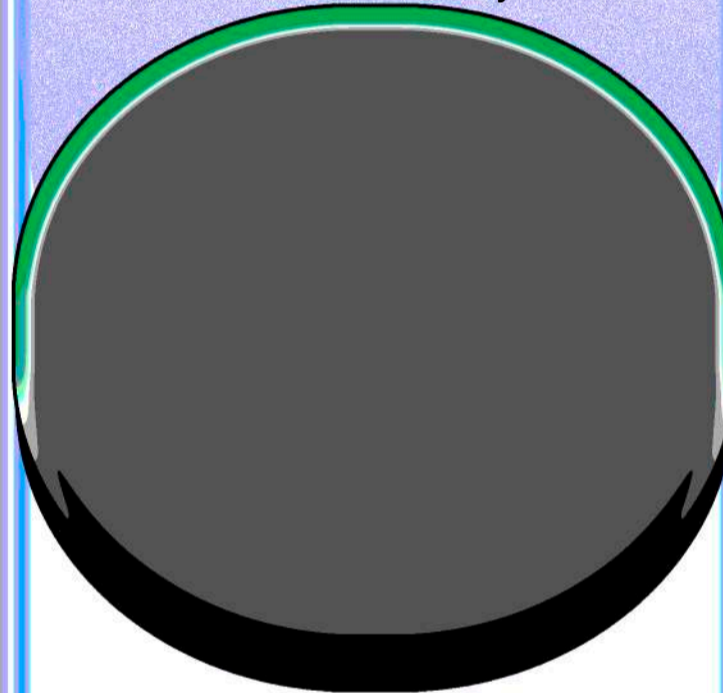

15

16

17



[4] I borrow the term from Mary Louise Pratt, who defined *contact zone* as "the space of colonial encounters, the space in which peoples geographically and historically separated come into contact with each other and establish ongoing relations,

usually involving conditions of coercion, radical inequality and intractable conflict. (...) By using the term 'contact' I am to foreground the interactive, improvisational dimensions of colonial encounters (...). A 'contact' perspective emphasises how subjects are constituted in and by their

relations to each other (...), often within radically asymmetrical relations of power." See Mary Louise Pratt, *Imperial Eyes: Travel Writing and Transculturation* (New York: Routledge, 1992), 6-7.

All your ancestors are within you.
All of them live in this pool of ancestral waters.
This river running from penis to penis
in a great chain of penetrations.

EARTH: THREE INDUSTRIAL TEMPLES

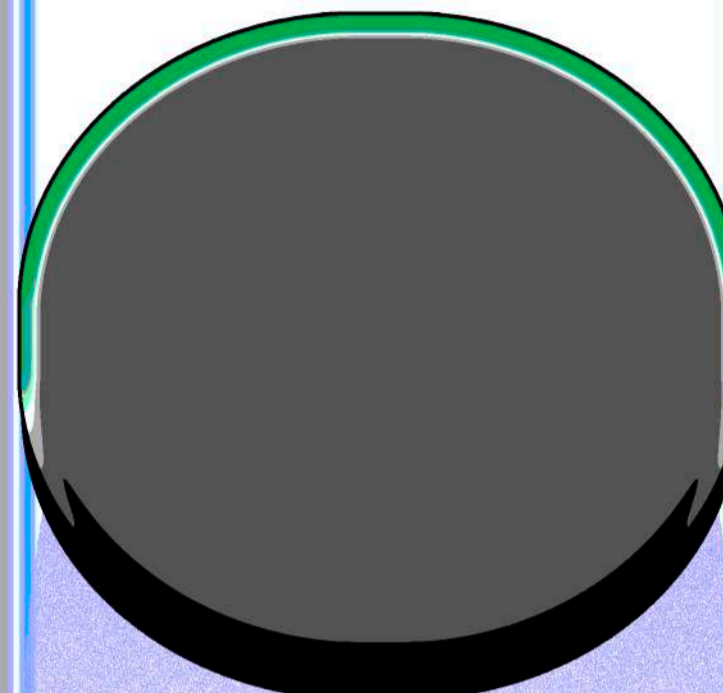

There is some irony in the fact that hydropower companies have become, together with the oil and wood industries, a core agent in the discovery of indigenous and natural heritage in South America. Of course, they are also a core agent in its destruction. While uncovering burial sites, pre-Columbian objects and fossils of previously unknown whale species, they displace indigenous populations from their land. The extractive industries set natural resources into motion. But they also extract and mobilise our pre-colonial cultural heritage, indigenous communities, entire peoples, animal species and sacred plants; all of which are connection nodes to the land.

Take for example the infamous conflict between Endesa, the leading electricity company in Spain with substantial holdings in Latin America, and the Mapuche-Pewenche indigenous population in southern Chile. In 1998, countless acres of sacred land were flooded in the construction of a hydroelectric dam, displacing the Mapuche communities that inhabited this region since times immemorial. In a matter of weeks, indigenous burial grounds and medicinal forest gardens disappeared alongside thousands of years of bio-cultural heritage, inextricably bound to this land. Everything was buried under

hard industrial waters, confined inside a colossal neo-temple made of concrete. Today Mapuche activists fight hydropower companies threatening their sacred land all across Chile.

In the Brazilian Amazon, increasing deforestation reveals hundreds of formerly unknown indigenous geoglyphs. And further west, one finds yet another temple of extractivism in Potosí, Bolivia. Although this time it's a temple built from earth: Our Lady of Cerro Rico (which means "Rich Hill", in Spanish). Here the Pachamama is cut down to her most intimate organs. The 18th-Century painting that depicts the Virgin Mary fused with this infamous silver mine is a shocking, anonymous, colonial image. Sometimes reality is not enough and only art, fiction, delirium are in a position to tackle the problem.

In the painting, the Virgin Mary embodies and contains within herself the silver mine. In this way, the Pachamama, Catholicism, colonial extractivism and the origins of capital collapse in a single image. Also known as Sumaj Orcko ("Beautiful Hill", in Quechua),

Cerro Rico was the most productive silver mine in the American colonies. Here the mountain is a container of resources, but also a woman's body. The hill stands for the Virgin Mary, but it's also the Mother Earth, Gaia, a fertility symbol. Not only is the hill being extracted, but so is the Earth, the Pachamama, its feminine energy.

There is no way to know exactly how much of the silver that circulates at a global scale comes originally from that mine. But this much is certain: Cerro Rico paved the way for modern capitalism and financial globalisation. There, in the middle of the arid Altiplano, was the most fertile mine of all the colonies. At the peak of its extractive frenzy, which saw about eight million native people die, Potosí was once the most densely populated city in the world. There are even chronicles that report the existence of toilets made of silver. The secret of what Marx called the "primitive accumulation of capital" is that settler-colonists literally shat on their own abundance.

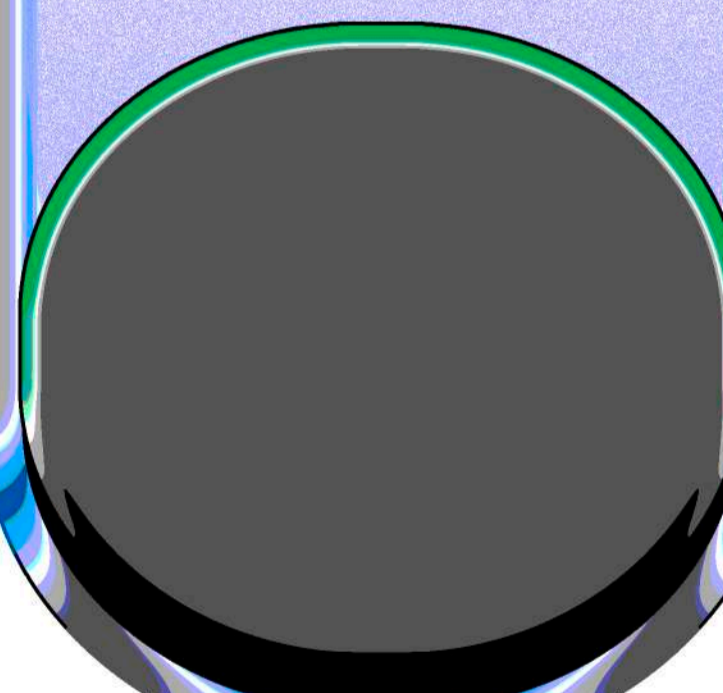
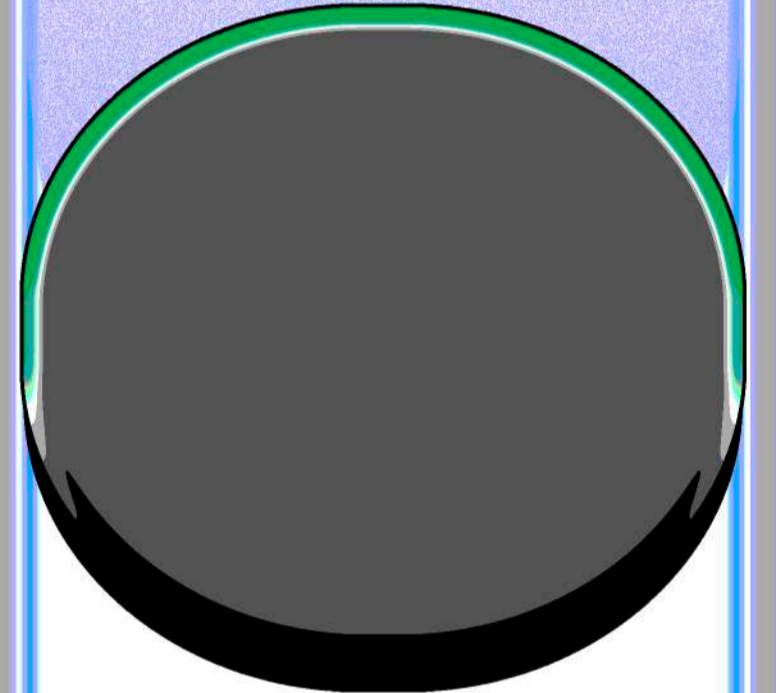

18

19

20



From uterus to uterus,
until you were made.

There is not much left in the bowels of the mine. But in 2019, there are still miners in Potosí who live and die under the worst conditions. They chew coca leaves to keep up their energy while working in the dark underbelly of the world. *I saw them myself.* At the mine's entrance, I saw libations of llama blood poured onto the earth as an offering. Llamas are offered in sacrifice to the mine as a way to satiate the earth, so that it doesn't swallow the miners. Despite all the work, they are lucky if they find any leftover crumbs of silver.

Leaving Potosí and the mine behind, we travelled northwest towards Puerto Maldonado, in Peru. We made a stop in Cusco and there we found the third temple.

Looking for an ATM, Marco arrived at the Museo de Sitio Puka Marka. He was told that the museum's ATM was

the only one that would read his debit card. The museum was literally inside Scotiabank's head office in Cusco and had on display all the archaeological artefacts that were unearthed during the construction of the bank. Back in 1944, Banco Wiese Ltda —later acquired by Scotiabank— built its head office on top of the ruins of an Incan palace, erected in the 15th Century by the tenth Sapa Inca of the Inca Empire, Túpac Yupanqui. Since 2006, Scotiabank is the legal custodian of this site's heritage.

While queuing for the ATM, one can see the image of a lightning bolt striking the exact spot where archaeologists discovered a four-legged ceramic vase, the only one of its kind. A sci-fi looking plastic bubble protects a hole dug into the earth. Long before Scotiabank even existed, the earth was the original custodian of the vase. Life admin and bureaucratic queues collide

in a vortex with indigenous burials. In one same space-time of epistemic extractivism, the limits between dimensions become tangled and blurred. There is a line to pay your debts, a line for cheques to be cashed, a line to enter the museum, and finally, a cosmic ray that strikes the earth, pointing to the original location of an indigenous ceremonial vase.

Beneath the earth lie the remains of an Incan palace. Above ground, a temple of neoliberalism stands on the exact same spot. Overlaid on top of each other, they are both part of an incoherent amalgamation. Their markings and erasures, uses and histories coexist on the same plane of existence. *The bank is a vortex of connection.* I feel the vertigo of space-time unfolding in this ceremonial site.

DEADLINES: DRONES



*THERE ARE HEALING VASES BURIED ALONGSIDE THEIR OWNERS.
THERE ARE MINERS EXTRACTING SILVER FOR FOREIGN EMPIRES.
THERE ARE BODIES WAITING TO GET A REBOOT FROM THE EARTH.
THERE ARE STARBUCKS CUPS WAITING TO GET TO A
RECYCLING CENTRE.
THERE ARE CERAMICS STARING AT TOURISTS THROUGH A GLASS CABINET.
THEY ARE A REMINDER THAT THERE IS NOT ONE
BUT MANY MODES OF EXISTENCE.*



21



22



23

ON THAT NIGHT, NOT SO FAR FROM THE MADRE DE DIOS RIVER, AS WE APPROACHED THE PERUVIAN AMAZON, I HAD A DREAM.

DRONES SURROUNDED ME.

EACH OF THEM HAD ONE RED EYE, LIKE A CYCLOPS.

JUST ONE EYE, RED AND TIRED. IRRITATED.

I COULDN'T HELP BUT FEEL A SENSE OF FAMILIARITY. DID THESE DRONES BELONG TO ME? THEY FELT A BIT LIKE PETS OR CLOSE PRESENCES. EVERY PERSON IN MY DREAM HAD THEIR OWN CYCLOPS-EYED DRONE FLYING AROUND THEIR HEADS. SOME OF THEM WERE LARGER THAN OTHERS. WITH ATTENTIVE EYES, THEY WATCHED OVER US, KEEPING TRACK OF OUR BUSY SCHEDULES IN REAL TIME. DRONES STALKED US LIKE BLOOD-SUCKING INSECTS, REMINDING EVERYONE OF THEIR TASKS, DUTIES AND DEADLINES.

EACH DRONE HAD ONE RED EYE, IRRITATED, WEEPING.

TEARDROPS FELL ON MY HEAD.

WHERE ONCE ARROWHEADS WERE PRODUCED, NOW WE FIND DRONES. BOTH DRONES AND ARROWS ARE FLYING MACHINES, WAR MACHINES. THEIR FLIGHT OF INVENTIVENESS CONTINUES, TAKING NEW AND UNEXPECTED FORMS. IT'S AN ANCESTRAL FLIGHT BEGUN WITH THE MOST RUDIMENTARY OF TECHNOLOGIES. THE WHISTLE OF AN ARROW RESONATES IN THE HUMMING OF EVERY DRONE.

While I follow the adhesive tape lines on the floor that guide me through the bank's premises, I also reconnect with the earth beneath my feet.

Next to the museum-cum-ATM, there is a newly open Starbucks. Thirsty customers ask the baristas for soya milk and drink their coffees while texting their significant others. As everyone knows, the key product at Starbucks is not coffee but open Wi-Fi networks. While customers send pictures of the Sacred Valley to their friends and families in the old continent, not so far from Cusco, Amazon rainforests are devastated to produce the transgenic soya that we drink with our lattes. Here in this Starbucks and elsewhere, there is a relentless circulation of images, texts and emojis from one land to another. Even if we are on holiday, deadlines continue to dictate everyday life. There is an infinite extraction of resources from the earth, from our bodies, from our intimate lives and affects. *I want to rest in silence beneath the ground. Let no wireless signal reach me.*

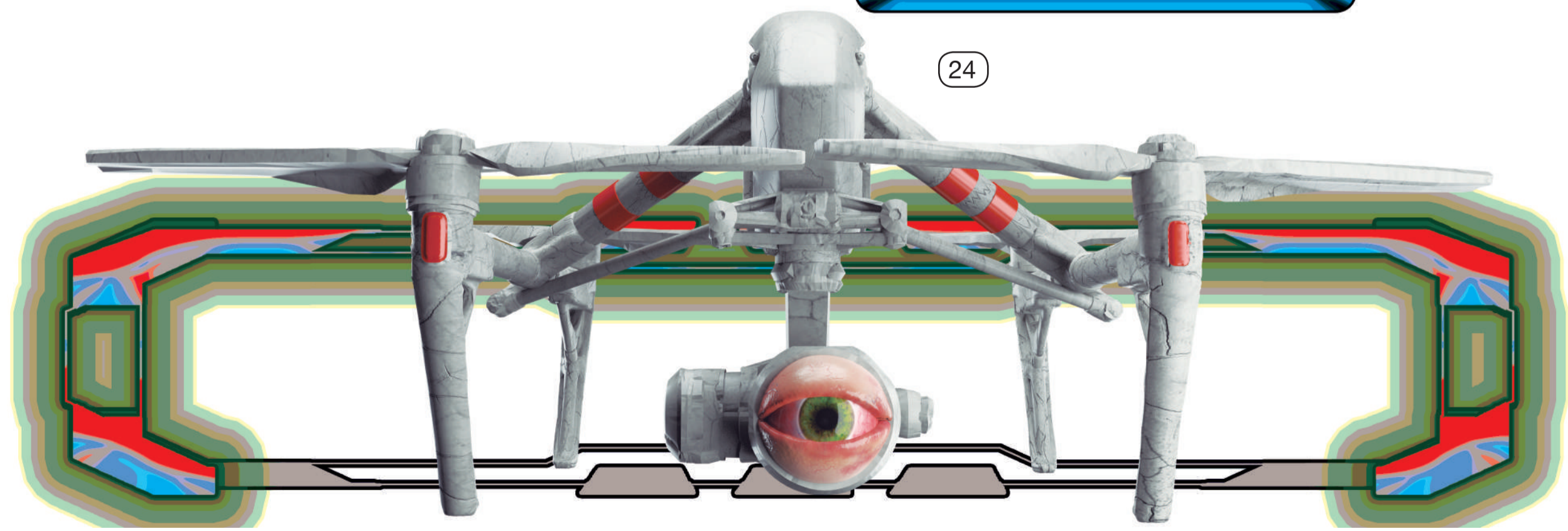

24

The ceramic vase is decorated with 64 lines.
Each of them finds its way into a striped corporate shirt.
Their geometric patterns threaten to reprogram me.
They want to change my energy matrix,
my personal code.

They induce visions in me. They induce phosphenes in you.
I take these holograms and patterns involuntarily.
Their abstract designs hypnotise me,
piercing through me, making me delirious.
I want to change my original code.

ROSES:

José Luis told us of the time he healed a wealthy Mexican businessman using roses. During the therapy, the man had a dream. It was revealed to him that he should buy a hill and build a chapel to honour the rose. The chapel would become a sanctuary, an *etheric temple*. Not long after this, he bought some hill land and soon began the construction work. He also acquired the patent of a rose that doesn't fade and made a hologram of this flower to be projected inside the temple. Eventually, he struck oil while building the temple. So he decided to open a petrol station next to this sacred space. The man couldn't possibly profit from roses, but he does from oil. That's how he supports the temple now. *That's how the temple supports us.*

When I am back in Mexico, I want to visit that place. I want to step through that portal into oil extraction and roses. *I want this place to fill me with holy petrol. I want to make a pilgrimage to a temple devoted to the worship of fossil fuels, which feed the engines of cars, and roses that feed the souls of people. I want to visit this temple of bio-exploratory drilling.*

The day I started learning from José Luis there was not a single rose in the town of Puerto Maldonado. They only arrived on the second day of lessons. José Luis told us how he first channelled his technique for healing with roses in a state of reverie, *between wake and dream. That's how the insight arrived.* In this transitional state, he learned the basics of healing with roses, channelling his technique from Our Lady of Guadalupe. *It has been said that culture develops through dreams.*

Speaking of Our Lady of Guadalupe, her feast day is December 12. A double twelve signals a sacred date, as both numbers add up to three. In 2019, a third three is added. The sum is as follows: 9 + 1 = 10, which equals one as the zero cancels itself out. Add the remaining two and you will get a third three. This is a 3-3-3 combination. This is an energy portal Opening this year on December 12. For your information.

Introduced by Europeans, roses acquired a magical power in the colonial imaginary through the legend of Our Lady of Guadalupe, who chose this flower as a symbol to manifest herself to Juan Diego, the first indigenous saint from the Americas.

Today in South America, rituals with roses are used to decolonise bodies and heal them from trauma. *To heal those of us embodied here, in this contact zone.* Symbolising feminine energy, roses are also employed to treat the emotional wounds and physical trauma caused by neoliberalism in the body.

Healing with roses is one of many mestizo rituals emerging in the contact zones between different cosmologies. By means of this ritual, the patient's relation with the social world is brought back to balance. In most countries in the Global South, access to health-care is radically uneven in comparison to the Global North. In Chile, health is managed as a consumer good and illness becomes an opportunity to make profit. *When I feel sick, I must think twice before going to the doctor.*

Since not even penicillin was available in some countries, the 1978 Declaration of Alma-Ata recommended making use of medicinal plants and ancestral knowledge to implement self-care while public health systems improved. It's often this need to resort to alternative means that leads us to explore rituals with roses, healing plants and other uses of the vegetable world. It's in our vegetable destiny to invent new forms of care.

In healing therapies with roses, flowers are placed on the patient's body to treat physical and psychological trauma. For example, it's possible to liberate emotions by placing roses on the chest. One's past, present and future can be cleansed by placing a rose behind the head, another rose on the forehead, and a third one in the chest. *Clear my calendar! Clean up my email!* For the so-called bridging technique, two roses are placed on a person's back, one facing downward and one facing upward, in order to generate a circuit that rebalances one's energies. Another technique consists of covering the patient in rose petals and then running a rose all across their body, calling the soul back to it.

According to José Luis, a rose has the potential to raise the frequency of human electrical fields when placed in contact with one's body, bringing us back to our original state and repairing the body's energy flow. Roses have travelled across the Atlantic Ocean to rid us of our cosmic weariness. They cleanse the energy all around us. They are active agents in earthly recycling.

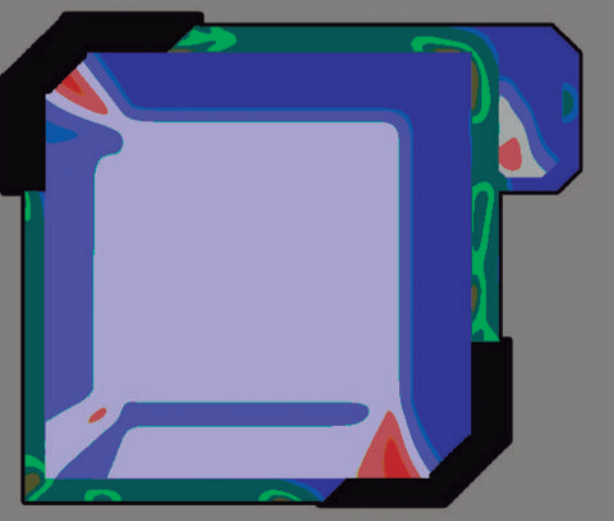
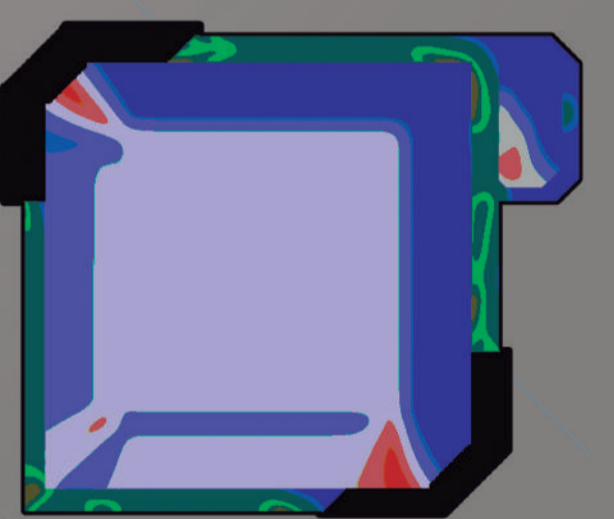

a WORD MISPLACED

To perform some measurements, José Luis employs a puzzling device called Calibrated Frequency Monitor:

The rose has the highest vibration frequency at 320 MHz. Lavender is next at 118 MHz. Tinned tuna vibrates at no more than 5 MHz. Hamburgers at 3 to 5 MHz. Coca-Cola, a drink that used to open all my portals, has the lowest vibration frequency at 0 Mhz. (I eventually managed to quit Coca-Cola, but Red Bull is now my portal opener. *Weep for me, duck-shaped vase! For I'm no longer tired!*) In normal conditions, the human body's frequency is somewhere between 62 and 78 MHz. Human cells can undergo mutations at any frequency lower than 62 MHz, José Luis warns me. If his Calibrated Frequency Monitor registers anything below 20 MHz, one is probably dead.

But it's not only high-frequency plants that heal us. Common trees and plants such as the pine tree or the eucalyptus can also activate healing processes. Plants are fundamentally neutral. Everything depends on how they are used and how they choose to express themselves. Plants call for order. They are themselves a product of spontaneous order. They tend toward spontaneous balance and health. *Even when they are planted in orderly rows.*

The rose knows what she is doing. If a thorn pricks you, check if you are doing what is right for your energy field. Speaking of thorns, when I went to the market of Puerto Maldonado, in order to find roses for my lessons with José Luis, I noticed they now sold bottles of water of the seven thorns. This green potion made from cactus thorns is traditionally used as an ointment, providing with magical protection against envy. *Now it is bottled and produced at industrial scale. Industrial farming of sacred plants for globalised markets.*

Some say that illness is just "a word misplaced in the body".⁵ In order to heal, it is necessary to identify that interference and remove the wrongly placed word. It's necessary to relocate a harmful word.

It is also said that healers, shamans, witch-doctors, *curacas* and sorcerers are the ones equipped with the know-how to re-establish harmony once it's lost. For them "every sacred thing must be in its place".⁶ I wanted to learn with Amazonian bio-healers. This is what brought us to the Madre de Dios River in the first place.

I just had my wireless network at home upgraded to 5G. The technician said that the vibration frequency of water is 2.8 MHz. Water running through pipes vibrates at the same exact frequency. As microwaves, mobile phones and the now-dated Wi-Fi. They all converged in the same energy flow. 5G must have been necessary For their paths to diverge.

Among the biotechnologies at play in the Madre de Dios River are those rituals practiced by healers like Amador, a man who gave us smoke baths and flower baths. The night we met, Amador showed us a bag of amulets inherited from his father. In the bag he carried a crown made of jaguar skin, a crocodile head, maracas, snails, several fragments of tapir and anaconda, a cluster of feathers and leaves, a necklace in the shape of a bird, another one made of jaguar skin, a waistcoat made by the Shipibo, a metal cross, a box of cigarettes, a bottle of Coke and a candle. *Amador also learned from his dreams.*

Apparently, he used the Coca-Cola in this shamanistic first-aid kit to stop the effects of his treatment when it became too powerful. He told us that Coke effectively shuts any portal into other dimensions. And to think I drank this for so many years! *It must have opened my portals to matter, to earth.*

The Lucky Strikes in Amador's bag were used for diagnostic purposes. He scanned our energy with his hands and the smoke from a cigarette. He would touch your body, exhale the smoke from a cigarette and follow its way upward with his hands. *Smoke was his primary telecommunication system.* He touched our navels and organs on both sides in case there was a *false heart*. As it turns out, I had one of those under my navel. A false heart is a throbbing, pulsating accumulation of negative energy that results from everyday worries such as those involving your parents, siblings, family. *"Taking a psychic break from one's clan demands a lot of courage"*, Amador told me. And he excised the false heart.

The smoke of Amador's cigarette told me I had to reach beneath my skin, reach beyond my face, to the depth of my being.

[5] This idea is central to the Mapuche cosmology. I heard about this in the symposium "Formación Farmacia Viva", organised by Fundación Alquímica in Santiago, Chile, 2019.

[6] Observation made by an indigenous thinker. Quoted in Claude Lévi-Strauss, *The Savage Mind* (1962).

Within the 960 spreadsheets there are 87 phones vibrating. Waiting to be answered. Within each phone there are 5 emojis who are offered cigarettes and 3 pictures popping-up in your hologram.

We will remove those images that have been placed on you. Out! Immediately and permanently. We shall bring you back to order. To your order. Your order.

ROSE

ESSENCE

ESSENCE

25

[IN HEALING THERAPIES WITH ROSES
FLOWERS ARE PLACED ON THE PATIENT'S BODY
TO TREAT PHYSICAL AND PSYCHOLOGICAL TRAUMA.]

ROSE

ESSENCE

ESSENCE

[FOR EXAMPLE, IT'S POSSIBLE TO
LIBERATE EMOTIONS BY PLACING ROSES
ON THE CHEST.]

1. Healing Earth Center

Anti-inflammatory pineapple leaves are good for tachycardia and irritable bowel syndrome.

Keep leaves in your shirt pocket for 3 hours a day.



2. Nomad Travel Clinic

Single palm tree leaf brings cooling breeze to alleviate stiff hands and arthritis.

Attach it to the back of your chair for 16 days.



3. Freedom Clinic

Chicken feathers to release stress and anxiety caused by overworking.

Attach 5 feathers to your hand and stroke the ground.



26

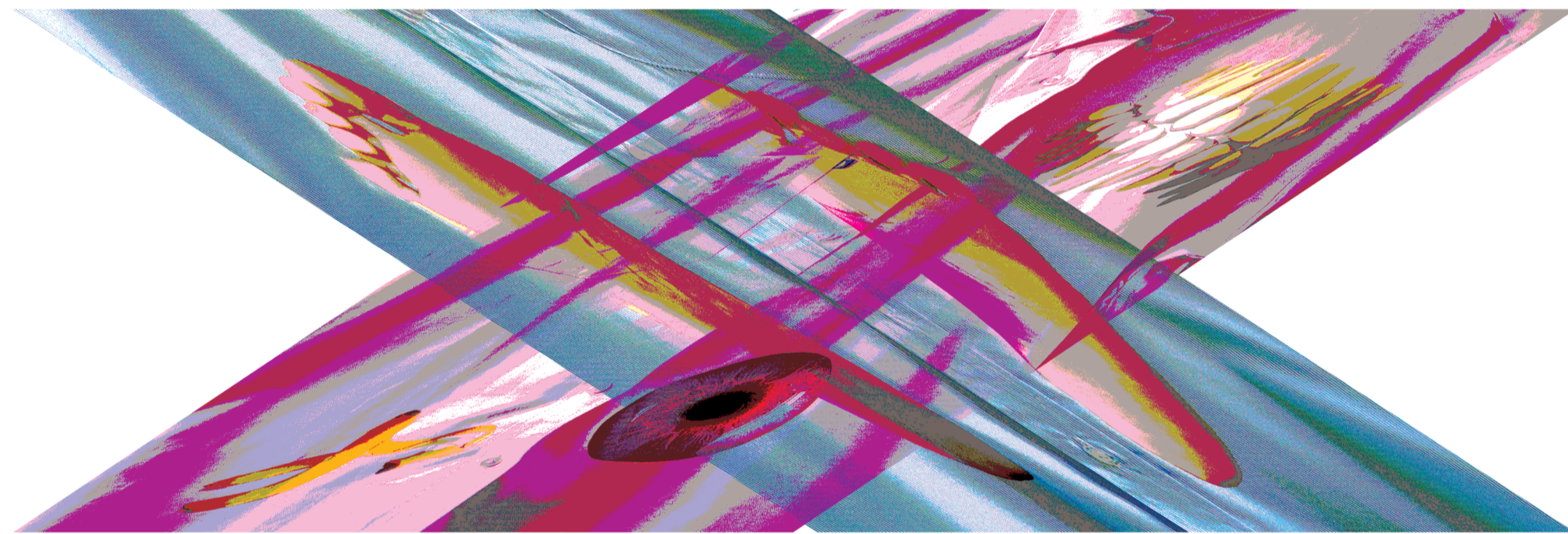

4. Island Health Clinic

Rose of Jericho to clean electromagnetic fields from Wi-fi.

Sprinkle around the office.



5.1 Vital Skin Clinic

Aloe vera to hydrate tired eyes. Jackfruit to relieve pressure in your head and erase face wrinkles.

Pin them continuously to transfer your pains into the plants.



5.2 Mobile Male Massage

For treating back pains.

Rub ceramics on spine.



Restore yourself,

The smoke showed me that my dark side and all my negative thoughts are stored in my right hip. Which helped explain why it hurts so much, so often. Amador healed the pain. *I told Amador that I was but an intruder on this land. He said that the earth does not see colour, it sees only offerings and gestures.* Download this to your most intimate self and let yourself feel it.



27

The flower bath felt like an immersion or a rebirth in the Pachamama. Amador purified our bodies with a combination of holy water, flower water, rue water, kanaka water, rose petals, spirit flowers, water of the seven powers and water of the seven churches. While we bathed, he invoked a litany of teachers, ancestors, medicinal plants and healers.

One of the many healers invoked was Cabeza de Vaca, a figure that embodies all the complexities, contradictions and complicities that define any colonial process.⁷ Alvar Núñez Cabeza de Vaca went from conquistador to shaman, becoming a hybrid out of sheer survival. Shipwrecked in 1528 off the coast of Florida, there were only four survivors of a crew of more than four-hundred. The three white men and Estebanico, an enslaved African man, were taken prisoners by the Caranaguas. They were the first colonisers who made their way into the southwest of what today is United States and the northwest of Mexico. Estebanico was probably the first African to set foot in North America.

During six years in captivity, Estebanico and Cabeza de Vaca learned the

local ritual practices, combining the Lord's Prayer and the Hail Mary with indigenous healing techniques such as that of blowing away an illness. That's how Cabeza de Vaca eventually managed to heal the son of a tribal chief, who set both of them free in return. Their fame was such that townspeople in the villages waited for them to heal the sick on their way to New Mexico, while they crossed the continent from east to west on foot. *They were healers out of sheer necessity and convenience; but healers nonetheless.* With the passing of time, Cabeza de Vaca became one of the few and earliest allies of indigenous rights in Europe, although it cost him a jail sentence and his later exile.

He is also one of the earliest figures in Latin America to embody radical syncretism and hybridisation through the practice of healing, thus making him a forerunner of the mestizo cultures that emerge in the overlaps and interstices between radically different worlds. It is then no surprise that Cabeza de Vaca continues to be named in litanies to this day.

The Americas are a multiverse in constant change and recirculation. Mestizo rituals are assembled from scraps

of traditions that have been erased, absorbed, recycled, adulterated, transformed and re-signified from the time of Cabeza de Vaca to the time of Endesa and Scotiabank.

It is Saturday night and my eyes are dry from too many hours spent in front of a computer. The screen's blue light serves as a candle for my rituals. These devices sleep next to us, they mix with us, they communicate through us, they transform us. Their screens sustain our mode of existence.

The last issue of National Geographic features an article on the medicine of the future. I take it to bed with me. On page 78 there is a picture of American football player James Harrison in an acupuncture session, with his head resting between two phones. Neither the caption nor the article explain what are the phones doing next to Harrison's head and so close to the acupuncture needles, but there they are. Mobile phones are there even when we are sleeping. They are there when we wake up. They are there when we are healing. They are here, next to us.

I turn on my made-in-China LED therapy mask and set it to a green light frequency. I was told that I should irradiate myself in green if I want to see what a plant sees. Green LED light seeps through my pores. It penetrates my most intimate self. It *greens* my soul. It reminds me that I do have eyes of plants, even though my upbringing might have projected something else for me.



28

*TOGETHER WITH A DUCK-SHAPED VASE
TOGETHER WITH A ONE-EYED DRONE
WE WEEP AND GREET THE SEVEN CARDINAL DIRECTIONS:
NORTH, SOUTH, EAST, WEST,
THE CENTRE OF THE UNIVERSE,
THE CENTRE OF THE EARTH,
YOUR OWN PERSONAL CENTRE*

**MAY MY VOICE EXCITE
THE PARTICLES OF WATER THAT SURROUND US.**

^[7] See Aneta Ikononova, "Curanderismo y cristianismo en 'Naufragios' de Alvar Núñez Cabeza De Vaca (1542)" in Religare - Revista de Ciências das Religiões No. 6 (2009).

Reset yourself.



Image Credits

- [1] 3D model of tears. Rendered by Álvaro Muñoz. Santiago, Chile, 2019.
 [2] 3D model of duck-shaped vase. Rendered by Álvaro Muñoz. Santiago, Chile, 2019.
 [3] Diaguita burial at El Olivar archaeological site in La Serena, Chile, where human remains are protected by two camelids. Since the corpse was surrounded by several ceramic pieces, he could have been a shaman (perhaps even the owner of the duck-shaped vase.)
 [4] Still frame from the video, *Eyes of Plants*, 2019.
 [5] Still frame from the video, *Eyes of Plants*, 2019.
 [6] Herbal medicine package, Mercado de las Brujas, La Paz, 2018.
 [7] Herbal medicine package, Mercado de las Brujas, La Paz, 2018.
 [8] Drawing by Patricia Domínguez, 2018.
 [9] Still frame from the video, *Eyes of Plants*, 2019.
 [10] Still frame from the video, *Eyes of Plants*, 2019.
 [11] *Shapeshifting Lines*, Patricia Domínguez, 2018.
 [12] *Shapeshifting Lines*, Patricia Domínguez, 2018.
 [13] Still frame from the video, *Eyes of Plants*, 2019.
 [14] Still frame from the video, *Eyes of Plants*, 2019.
 [15] See: <<https://futurorenovable.cl/diagonal-contra-las-represas-el-caso-ralco/>>
 [16] *La Virgen del Cerro* (Our Lady of Cerro Rico), c.1720. Anonymous painting. Collection of Museo Nacional Casa de la Moneda de Bolivia, Potosí.
 [17] Scotiabank in Cusco, Photograph taken by Patricia Domínguez, 2018.
 [18] Workshop by Fundación Alquímica, Santiago, 2019. Photograph by Patricia Domínguez.
 [19] See: <https://www.enel.cl/es/inversionistas/inversionistas-enel-generacion/nuestras-centrales/ralco.html>
 [20] Scotiabank in Cusco, Photograph taken by Patricia Domínguez, 2018.
 [21] Scotiabank in Cusco, Photograph taken by Patricia Domínguez, 2018.
 [22] Scotiabank in Cusco, Photograph taken by Patricia Domínguez, 2018.
 [23] Scotiabank in Cusco, Photograph taken by Patricia Domínguez, 2018.
 [24] 3D model of a crying drone. Rendered by Álvaro Muñoz, Santiago, Chile, 2019.
 [25] Still frames from the video, *Eyes of Plants*, 2019.
 [26] Patricia Domínguez. My Spreadsheets Hurt, 2019. Printed corporate shirts.
 [27] James Harrison in *National Geographic*, Special issue entitled "El Futuro de la Medicina. Las nuevas tecnologías y los remedios ancestrales transforman la salud" (The Future of Medicine. New Technologies and Ancestral Remedies Transform Healthcare), January 2019.
 [28] Still frame from the video, *Eyes of Plants*, 2019.
 [29] Iris scan of the artist. Produced by Iris Love, Madrid. 3D rendered by Álvaro Muñoz, 2019.

TEXTS BY PATRICIA DOMÍNGUEZ.

EDITED AND REVISED BY SABEL GAVALDON.

WITH CONTRIBUTIONS FROM CLAUDIA BLIN, MARCO GODOY AND PAULA ILABACA

TRANSLATED BY SABEL GAVALDON AND RODNEY STRABUCCHI.

DESIGNED IN COLLABORATION WITH FUTURO.STUDIO ([HTTPS://FUTURO.STUDIO](https://futuro.studio))

PRINTED BY THE NEWS HOUND IN A EDITION OF 1500.

PUBLISHED BY GASWORKS, LONDON.

PRODUCED ON THE OCCASION OF THE EXHIBITION

"GREEN IRISES" AT GASWORKS, 4 JULY - 8 SEPTEMBER 2019.

PATRICIA DOMÍNGUEZ'S EXHIBITION IS COMMISSIONED AND PRODUCED BY GASWORKS, WITH GENEROUS SUPPORT FROM LAZO CORDILLERA, FUNDACIÓN ENGEL, FUNDACIÓN AMA AND SCAN.

GASWORKS COMMISSIONS ARE SUPPORTED BY CATHERINE PETITGAS AND GASWORKS EXHIBITIONS SUPPORTERS.

© Gasworks, 2019

Texts (CC) BY-NC-ND – Patricia Domínguez

Every effort has been made to contact the copyright holders.

If acknowledgement has not been made we ask copyright holders to contact the editors.

DISCLAIMER: THIS IS A WORK OF FICTION

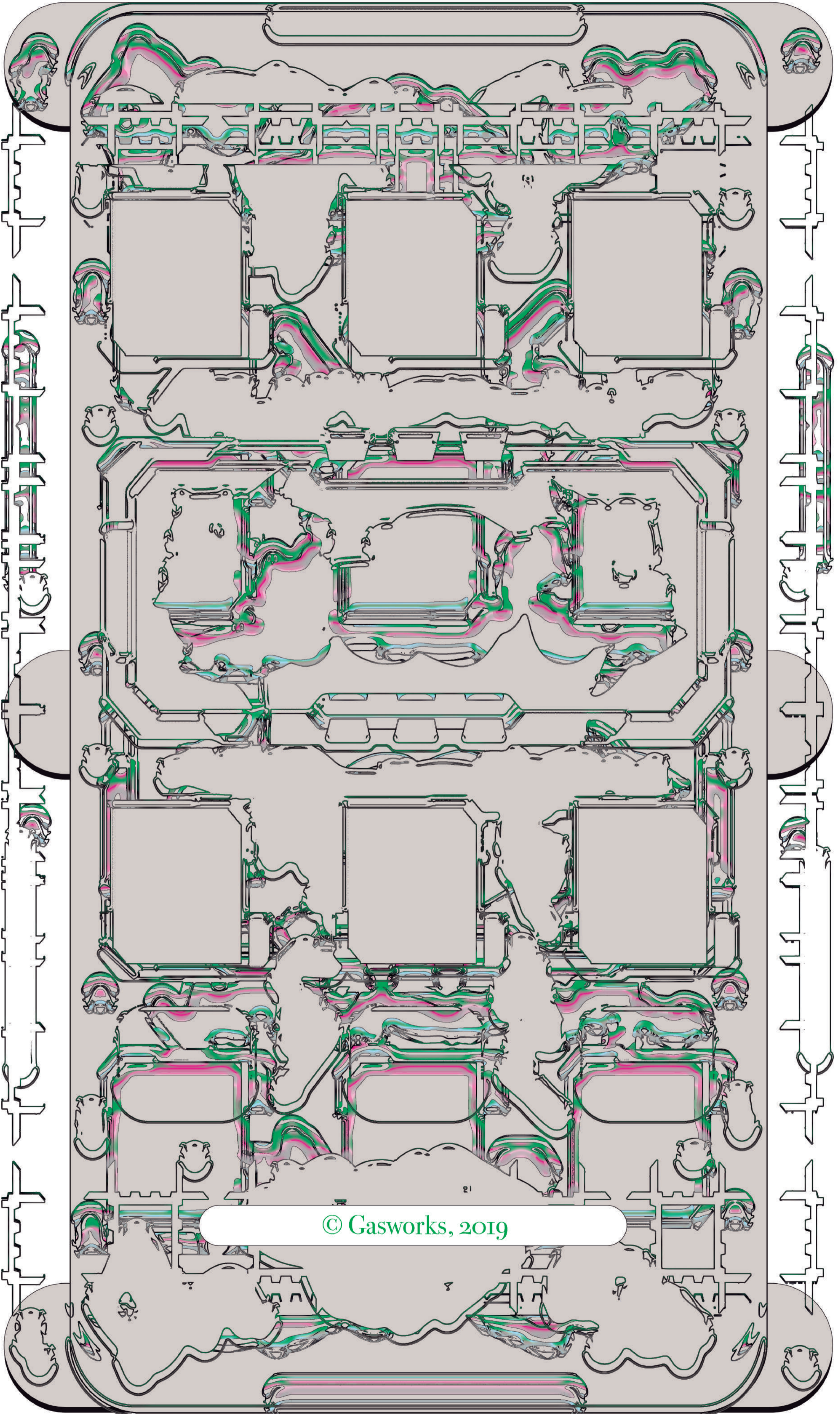

© Gasworks, 2019